



US 20060125389A1

(19) **United States**

(12) **Patent Application Publication**

(10) **Pub. No.: US 2006/0125389 A1**

Song et al.

(43) **Pub. Date:**

Jun. 15, 2006

(54) **ELECTROLUMINESCENCE DISPLAY DEVICE**

(30) **Foreign Application Priority Data**

Dec. 13, 2004 (KR)..... 10-2004-0104943

(75) Inventors: **Young-Woo Song**, Suwon-si (KR);
Yoon-Chang Kim, Suwon-si (KR);
Sang-Hwan Cho, Suwon-si (KR);
Ji-Hoon Ahn, Suwon-si (KR); **Joon-Gu Lee**,
Suwon-si (KR); **So-Young Lee**,
Suwon-si (KR); **Jong-Seok Oh**,
Suwon-si (KR); **Jae-Heung Ha**,
Suwon-si (KR)

Publication Classification

(51) **Int. Cl.**
H05B 33/00 (2006.01)

(52) **U.S. Cl.** 313/506

(57) **ABSTRACT**

An electroluminescence (EL) display device with improved external light coupling efficiency and brightness that may be easily manufactured. The EL display device includes: a substrate; a first electrode arranged above the substrate; a second electrode arranged above and substantially parallel to the first electrode; an intermediate layer arranged between the first and second electrodes, and including an emissive layer; a color converting layer arranged between the substrate and the first electrode or above the second electrode; and a light resonance controlling layer arranged between the emissive layer and the color converting layer.

Correspondence Address:
H.C. PARK & ASSOCIATES, PLC
8500 LEESBURG PIKE
SUITE 7500
VIENNA, VA 22182 (US)

(73) Assignee: **Samsung SDI Co., Ltd.**

(21) Appl. No.: **11/298,569**

(22) Filed: **Dec. 12, 2005**

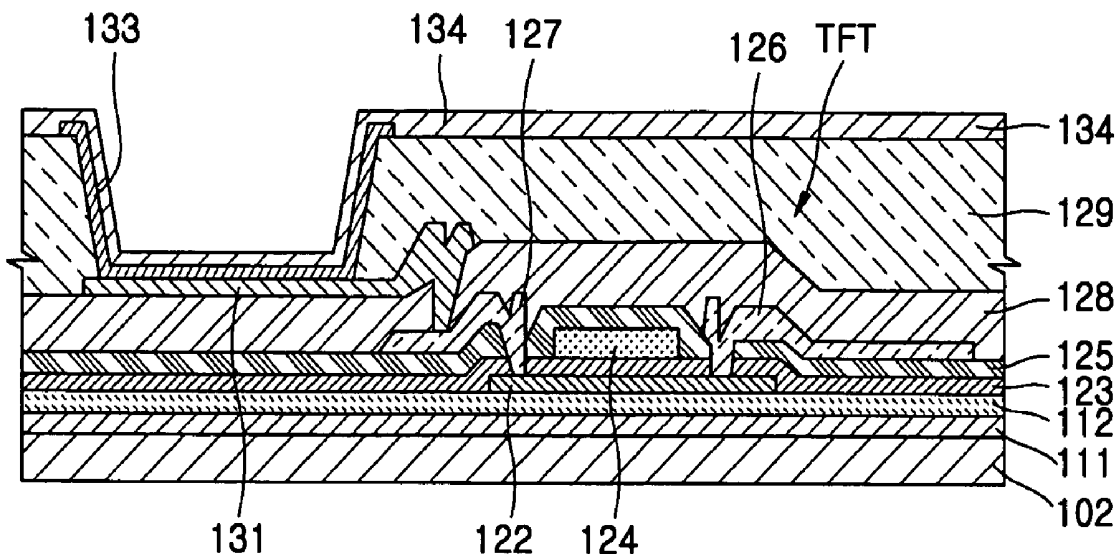

FIG. 1

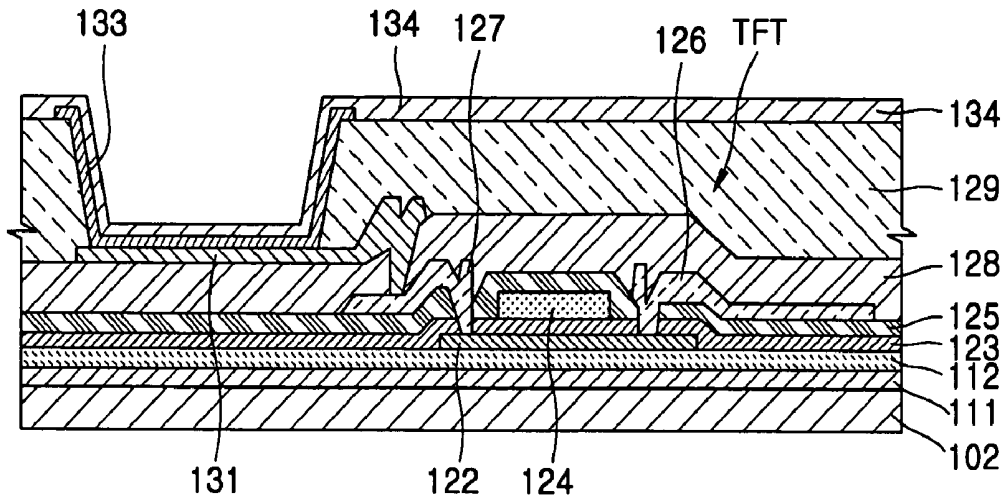

FIG. 2

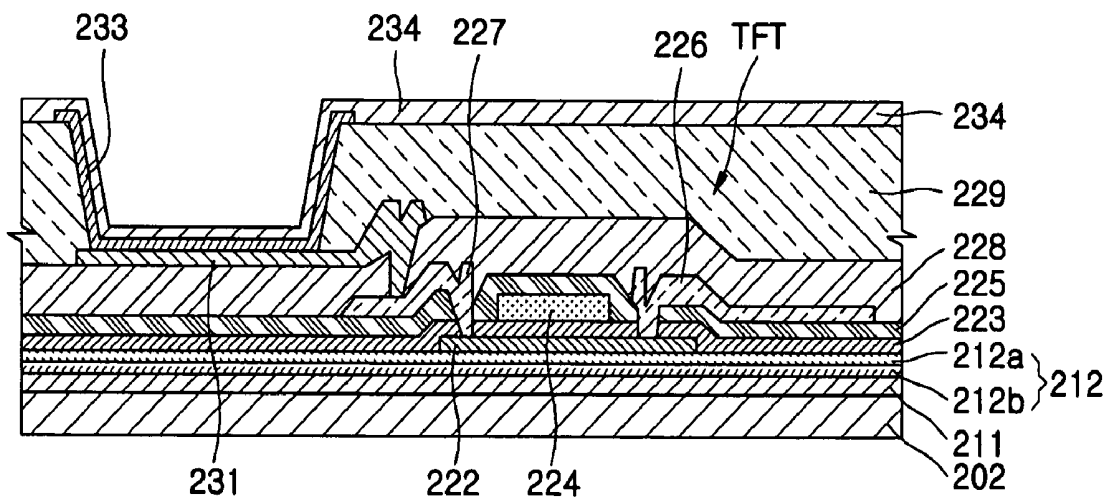

FIG. 3

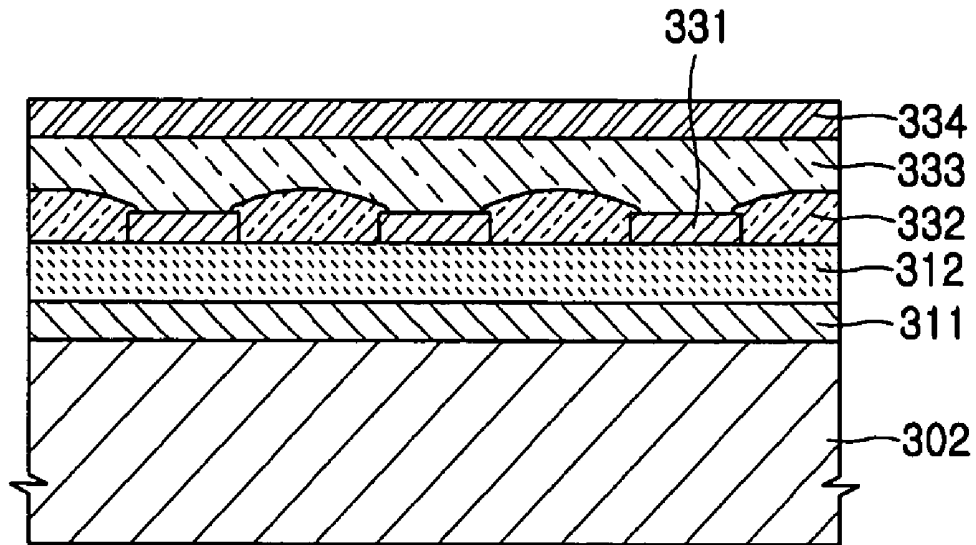

FIG. 4

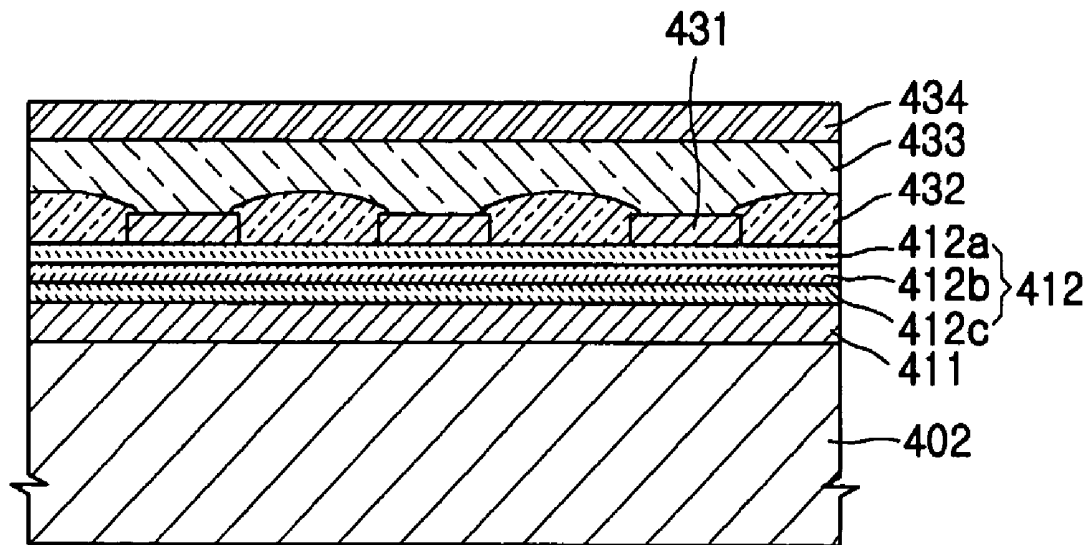

FIG. 5

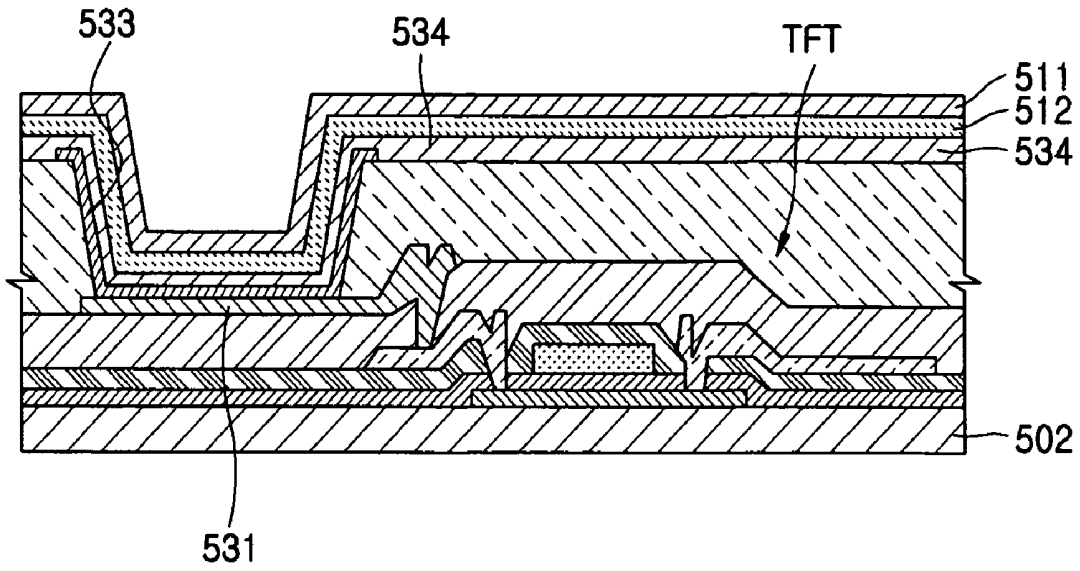

FIG. 6

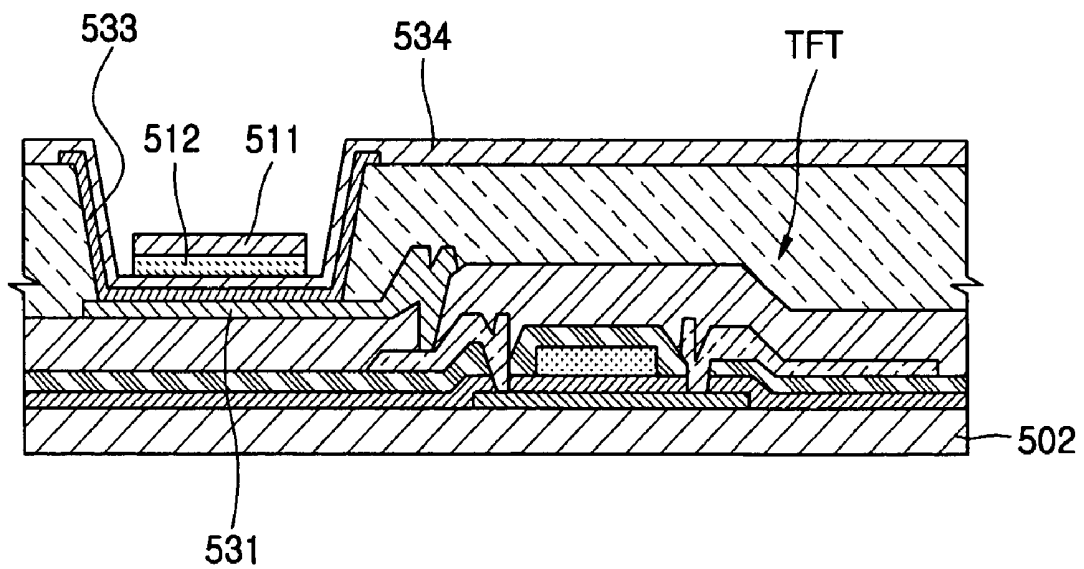

FIG. 7

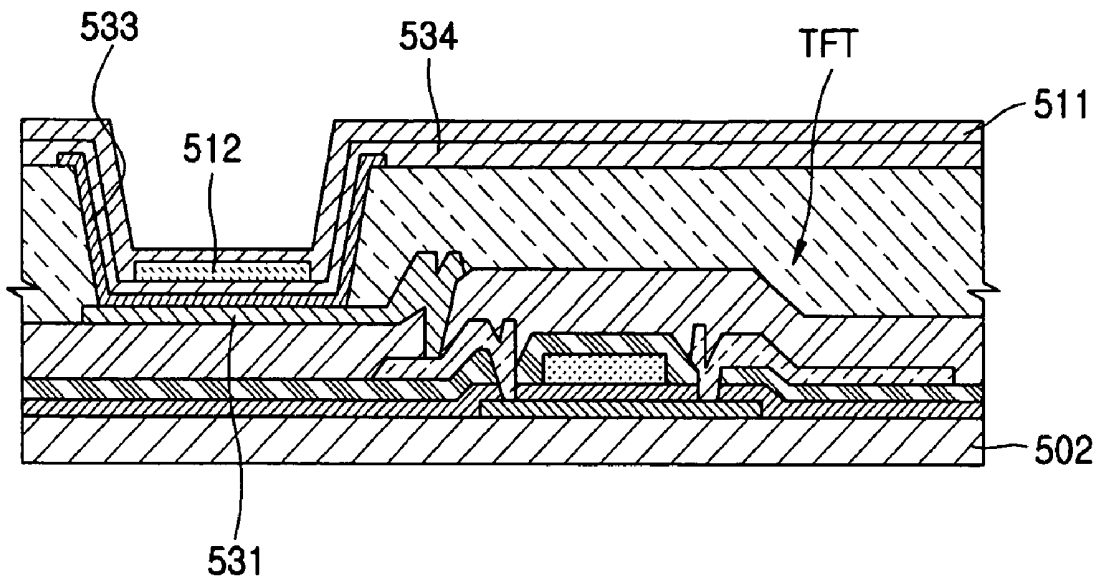

FIG. 8

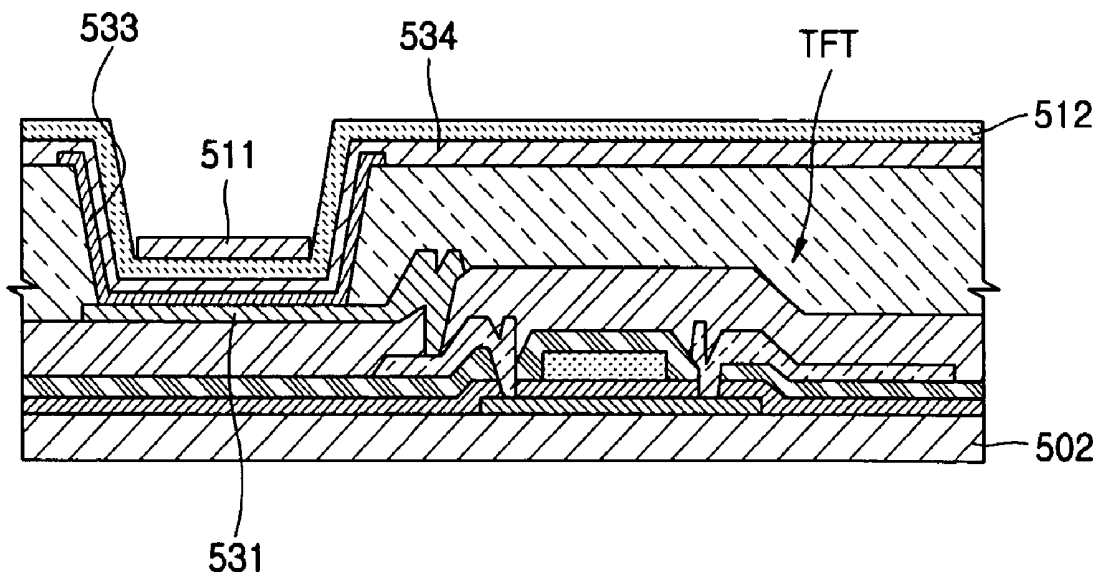

FIG. 9

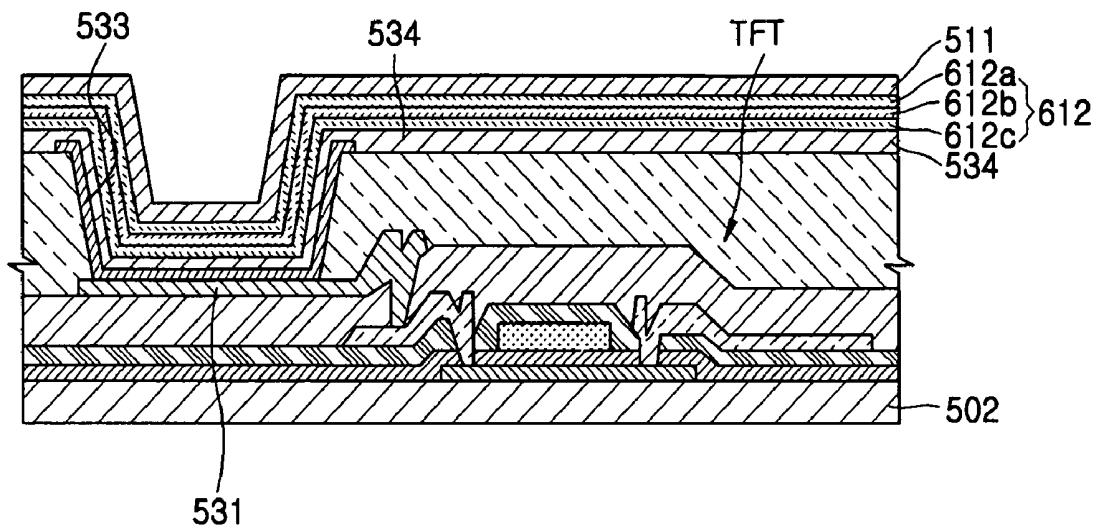

FIG. 10

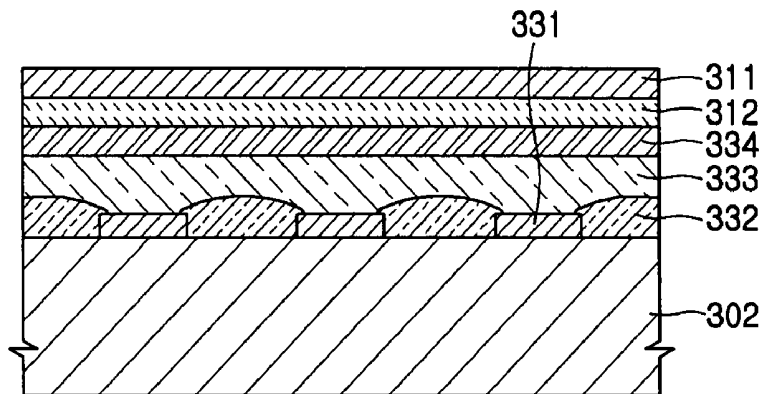
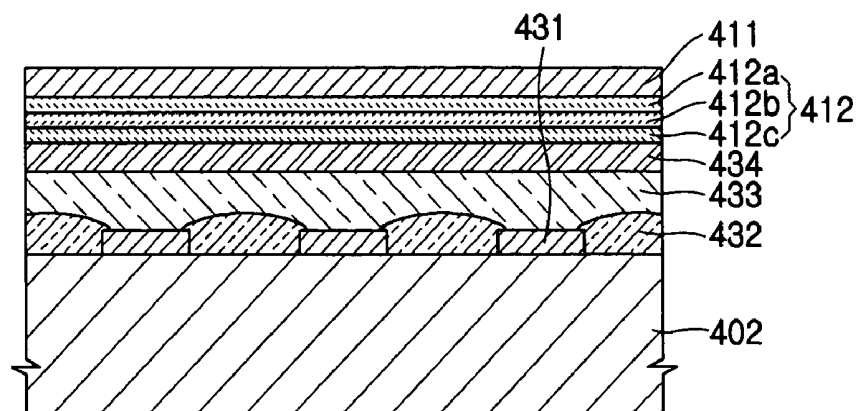

FIG. 11



ELECTROLUMINESCENCE DISPLAY DEVICE

CROSS REFERENCE TO RELATED APPLICATION

[0001] This application claims the priority to and benefit of Korean Patent Application No. 10-2004-0104943, filed on Dec. 13, 2004, in the Korean Intellectual Property Office, which is hereby incorporated by reference for all purposes as if fully set forth herein.

BACKGROUND OF THE INVENTION

[0002] 1. Field of the Invention

[0003] The present invention relates to an electroluminescence (EL) display device, and more particularly, to an EL display device with improved external light coupling efficiency and brightness that may be easily manufactured.

[0004] 2. Discussion of the Background

[0005] The external light coupling efficiency, η_{ex} , of an EL display device is given by the following equation:

$$\eta_{ex} = \eta_{in} \cdot \eta_{out}$$

where, η_{in} and η_{out} denote the internal quantum coupling efficiency and the output quantum coupling efficiency, respectively. The internal quantum coupling efficiency, η_{in} , is determined by self-elimination within each layer. The output quantum coupling efficiency, η_{out} , is determined by the prevention of light to the outside due to the total internal reflection in each layer (i.e., failure to transmit the light to the outside due to the total internal reflection occurring at an interface because an incident angle of the light is greater than a critical angle of the light when the light is incident from a medium having a higher refractive index as compared to another medium having a lower refractive index). In the EL display device, a light emitting layer transmits the light through many layers before emitting the light to the outside, where variations in the refractive indexes of the many layers prevent emission of some light.

[0006] The output quantum coupling efficiency, η_{out} , or the light transmittance efficiency which depends on the total internal reflection at interfaces between the layers when the emissive layer emits light to the outside, may be expressed as:

$$\eta_{out} = \frac{1}{2} \left(\frac{N_{out}}{N_{in}} \right)^2 \quad (2)$$

where N_{out} represents the refractive index of the emissive layer emitting the light, and N_{in} represents the refractive index of the emissive layer receiving the light. For example, the output light coupling efficiency of light transmitting through a layer with a refractive index of about 1.5 to a layer with a refractive index of about 1.2 is determined to be 32% using Equation 2, or about 70% of the light which enters the interface is not emitted to the outside.

[0007] There have been many efforts to prevent lowered external light coupling efficiency.

[0008] Japanese Patent Publication No. 4-192290 discloses an inorganic EL device where a plurality of condensing microlenses is the same size or larger than an inorganic

EL element. The plurality of condensing microlenses is formed on an external surface of a transparent substrate on which the inorganic EL element is formed. Light incident to the interface between the transparent substrate and air at an angle greater than the critical angle has an incident angle less than the critical angle on the microlenses, thereby reducing the total internal reflection. Additionally, the light is emitted in a predetermined direction to improve brightness. However, the cited invention discloses the EL element is a surface light source; thus, diffused light, which is not focused, inevitably occurs when using a microlens that is the same size or larger than the EL element. Clarity of an image is reduced due to overlapping images produced by the adjacent EL elements.

[0009] Japanese Patent Publication No. 7-037688 discloses an EL element formed on a substrate having a cylindrically-shaped high refraction factor section composed of a material having a higher refraction index than the surrounding material formed around the side surface of the substrate. Light produced by the EL element is emitted through the high-refraction factor section to increase external light coupling efficiency. However, in the cited invention, the light transmitted through the high-refraction factor section is diffused light, as illustrated in FIG. 1 of the cited invention. Thus, the brightness of the light emitted to the front is not improved.

[0010] Japanese Patent Publication No. 10-172756 discloses an organic EL light emitting device having a plurality of condensing lenses formed between a lower electrode, composing the organic EL light emitting device, and a transparent substrate. The organic EL light emitting device and the condensing lens are disposed in correspondence with one another. Light transmitted through the EL light emitting device is incident to an interface of the transparent substrate at a smaller angle than the critical angle for increasing the external light coupling efficiency. However, in the cited invention, overlapping images produced by adjacent EL light emitting devices reduce image clarity.

SUMMARY OF THE INVENTION

[0011] The present invention provides an electroluminescence (EL) display device with improved external light coupling efficiency and brightness that may be easily manufactured.

[0012] Additional features of the invention will be set forth in the description which follows, and in part will be apparent from the description, or may be learned by practice of the invention.

[0013] The present invention discloses an EL display device, including: a substrate; a first electrode arranged above the substrate; a second electrode arranged above and substantially parallel to the first electrode; an intermediate layer arranged between the first and second electrodes, and including an emissive layer; a color converting layer arranged between the substrate and the first electrode, or arranged above the second electrode; and a light resonance controlling layer arranged between the emissive layer and the color converting layer.

[0014] The present invention also discloses the emissive layer may emit blue light.

[0015] The present invention also discloses the color converting layer may convert light emitted from the emissive layer into one of red, green, and blue light.

[0016] The present invention also discloses the light resonance controlling layer may be a single layer.

[0017] The present invention also discloses a refractive index of the light resonance controlling layer may be lower than refractive indexes of layers arranged on the light resonance controlling layer and below the light resonance controlling layer.

[0018] The present invention also discloses the light resonance controlling layer may include at least two layers.

[0019] The present invention also discloses the light resonance controlling layer may include alternating layers having a low refractive index and layers having a high refractive index.

[0020] The present invention also discloses the color converting layer may be arranged between the substrate and the first electrode, and the light resonance controlling layer may be arranged between the color converting layer and the first electrode.

[0021] The present invention also discloses the color converting layer may be arranged above the second electrode, and the light resonance controlling layer may be arranged between the second electrode and the color converting layer.

[0022] The present invention also discloses the color converting layer may be arranged between the substrate and the first electrode and between the substrate and the second electrode, and the light resonance controlling layer may be arranged between the first electrode and the color converting layer arranged between the substrate and the first electrode, and arranged between the second electrode and a color converting layer arranged above the second electrode.

[0023] It is to be understood that both the foregoing general description and the following detailed description are exemplary and explanatory and are intended to provide further explanation of the invention as claimed.

BRIEF DESCRIPTION OF THE DRAWINGS

[0024] The accompanying drawings, which are included to provide a further understanding of the invention are incorporated in and constitute a part of this specification, illustrate embodiments of the invention, and together with the description serve to explain the principles of the invention.

[0025] **FIG. 1** is a schematic cross-sectional view of an electroluminescence (EL) display device according to a first embodiment of the present invention;

[0026] **FIG. 2** is a schematic cross-sectional view of an EL display device according to a second embodiment of the present invention;

[0027] **FIG. 3** is a schematic cross-sectional view of an EL display device according to a third embodiment of the present invention;

[0028] **FIG. 4** is a schematic cross-sectional view of an EL display device according to a fourth embodiment of the present invention;

[0029] **FIG. 5** is a schematic cross-sectional view of an EL display device according to a fifth embodiment of the present invention;

[0030] **FIG. 6** is a schematic cross-sectional view of a modification of the EL display device depicted in **FIG. 5**;

[0031] **FIG. 7** is a schematic cross-sectional view of another modification of the EL display device depicted in **FIG. 5**;

[0032] **FIG. 8** is a schematic cross-sectional view of another modification of the EL display device depicted in **FIG. 5**;

[0033] **FIG. 9** is a schematic cross-sectional view of an EL display device according to a sixth embodiment of the present invention;

[0034] **FIG. 10** is a schematic cross-sectional view of an EL display device according to a seventh embodiment of the present invention; and

[0035] **FIG. 11** is a schematic cross-sectional view of an EL display device according to an eighth embodiment of the present invention.

DETAILED DESCRIPTION OF THE ILLUSTRATED EMBODIMENTS

[0036] The invention is described more fully hereinafter with reference to the accompanying drawings, in which embodiments of the invention are shown. This invention may, however, be embodied in many different forms and should not be construed as limited to the embodiments set forth herein. Rather, these embodiments are provided so that this disclosure is thorough, and will fully convey the scope of the invention to those skilled in the art. In the drawings, the size and relative sizes of layers and regions may be exaggerated for clarity. In the drawings, like reference numerals denote like components.

[0037] It will be understood that when an element such as a layer, film, region, or substrate is referred to as being "on" another element, it may be directly on the other element or intervening elements may also be present. In contrast, when an element is referred to as being "directly on" another element, there are no intervening elements present.

[0038] **FIG. 1** is a schematic cross-sectional view of an electroluminescence (EL) display device according to a first embodiment of the present invention.

[0039] EL display devices are classified as passive matrix (PM) EL display devices with a simple matrix type or active matrix (AM) EL display devices including a thin film transistor (TFT) based on a method of controlling the emission of pixels. The EL display device in the present embodiment is an AM EL display device.

[0040] Referring to **FIG. 1**, a first electrode **131** is arranged above a substrate **102**, a second electrode **134** substantially parallel to the first electrode **131** is arranged above the first electrode **131**, and an intermediate layer **133** including an emissive layer is arranged between the first electrode **131** and the second electrode **134**. At least one TFT is coupled to the first electrode **131**, and a capacitor may be further coupled to the TFT, if required.

[0041] The substrate **102** may be made of transparent glass, but may also be made of acrylic, polyimide, polycarbonate, polyester, mylar, or other plastic materials. A buffer layer (not shown) made of SiO₂ may be further disposed on

the substrate **102** to maintain a smooth surface of the substrate **102** and prevent impurities from penetrating into the substrate **102**.

[0042] The first electrode **131** functions as an anode electrode and the second electrode **134** functions as a cathode electrode, or vice versa.

[0043] The EL display device of the present embodiment is a bottom emission EL display device in which light is emitted towards the substrate **102**. Therefore, the first electrode **131** is a transparent electrode made of, for example, ITO, IZO, ZnO, or In_2O_3 . The first electrode **131** may be disposed to correspond to sub-pixels. The second electrode **134** is a reflective electrode, and is made by depositing Li, Ca, LiF/Ca, LiF/Al, Al, or Mg, and compounds of Li, Ca, LiF/Ca, LiF/Al, Al, or Mg. The second electrode **134** may be disposed to correspond to each of the sub-pixels or may be disposed across the entire surface of the substrate **102**. In other embodiments described below, the EL display device may be configured, as described above for the bottom emission EL display device or the EL display device may be structured in other ways.

[0044] As described above, the TFT is connected to the first electrode **131**. The TFT includes a semiconductor layer **122**, a gate insulating layer **123** arranged on the semiconductor layer **122**, and a gate electrode **124** arranged on the gate insulating layer **123**. The gate electrode **124** is connected to a gate line (not shown) which supplies an on/off signal for the TFT. A region on which the gate electrode **124** is arranged corresponds to a channel region of the semiconductor layer **122**. The structure of the TFT is not limited to that illustrated in **FIG. 1**; various other structures of TFTs, such as an organic TFT, may be used.

[0045] An inter-insulator **125** is formed on the gate electrode **124**, and a source electrode **126** is connected to a source region and a drain electrode **127** is connected a drain region of the semiconductor layer **122** via a contact hole.

[0046] A planarization layer or a protective layer **128** made of SiO_2 is formed on the source electrode **126** and the drain electrode **127**, and a pixel defining layer **129** made of acryl, polyimide, polycarbonate, polyester, mylar, or other plastic materials, is formed on the planarization layer **128**.

[0047] Also, although not illustrated in **FIG. 1**, at least one capacitor is connected to the TFT. A circuit including the TFT is not limited to that illustrated in **FIG. 1** and may be embodied in various ways.

[0048] The drain electrode **127** is connected to an EL element. The first electrode **131**, which functions as the anode electrode of the EL element, is arranged on the planarization layer **128**; the pixel defining layer **129** is arranged on the planarization layer **128**, and the intermediate layer **133** including the emissive layer is arranged in a predetermined opening arranged in the pixel defining layer **129**. In **FIG. 1**, the intermediate layer **133** is patterned to correspond to only the sub-pixels; thus, the intermediate layer **133** may be integrated with an intermediate layer of an adjacent sub-pixel.

[0049] The intermediate layer **133** may be composed of an organic or inorganic material. If the intermediate layer **133** is composed of an organic material, the organic material may be a high molecular weight organic material or a low

molecular weight organic material. When the low molecular weight organic material is used, a hole injection layer (HIL), a hole transport layer (HTL), an emissive layer (EML), an electron transport layer (ETL), and an electron injection layer (EIL) may be stacked in a single structure or in multiple structures, where the organic material may be copper phthalocyanine (CuPc), N,N'-di(naphthalene-1-yl)-N,N'-diphenyl-benzidine (NPB), tris-8-hydroxyquinoline aluminum (Alq3), or the like. The low molecular weight organic material is provided in a pattern, as described above, and is formed using a vacuum deposition method using masks, such as those described above.

[0050] When the high molecular weight organic material is used, the intermediate layer **133** may include an HTL and an EML. The HTL may be made of poly-3,4-ethylenedioxythiophene (PEDOT) and the EML may be made of a high molecular weight organic material, for example, from the poly-phenylenevinylene (PPV) family and the polyfluorene family.

[0051] The structure and materials of the intermediate layer **133** may be applied to other embodiments described below, and variations of the intermediate layer **133** in the present embodiment may also be applied to other embodiments.

[0052] The EL element formed on the substrate **102** is covered by an element (not shown) substantially parallel to the EL element. The element may be made of glass or a plastic material similar to the material chosen for the substrate **102**, but may also be made of a metal cap.

[0053] A color converting layer **111** is arranged between the substrate **102** and the first electrode **131** or between the substrate **102** and the second electrode **134**. In the EL display device of the present embodiment, the color converting layer **111** is arranged between the substrate **102** and the first substrate **131**, as illustrated in **FIG. 1**, and is a bottom emission EL display device, where light emitted from the emissive layer of the intermediate layer **133** is transmitted to the outside via the substrate **102**.

[0054] A light resonance controlling layer **112** is arranged between the emissive layer included in the intermediate layer **133** and the color converting layer **111**. In the case of the EL display device according to the present embodiment, the light resonance controlling layer **112** is arranged on a surface of the color converting layer **111** substantially parallel to the intermediate layer **133** including the emissive layer, as illustrated in **FIG. 1**. Various other layers are arranged between the emissive layer included in the intermediate layer **133** and the color converting layer **111**, as illustrated in **FIG. 1**. Thus, the light resonance controlling layer **112** may be arranged between any two of the layers, as illustrated in the the structure of **FIG. 1**. This also applies to other embodiments described below.

[0055] The emissive layer included in the intermediate layer **133** is a light emitting layer which emits light of a single color, and the color converting layer **111** is a layer which converts the light emitted from the emissive layer into a color of light selected from the group consisting of red, green or blue light. The emissive layer included in the intermediate layer **133** may emit blue light. In this case, the color converting layer **111** may convert the blue light into red or green light or transmit the blue light without a color conversion.

[0056] The light resonance controlling layer 112 in the present embodiment is a single layer, where the refractive index of the light resonance controlling layer 112 is smaller than the refractive index of a layer arranged on a top surface of the light resonance controlling layer 112 and the refractive index of a layer formed on a bottom surface of the light resonance controlling layer 112. In the case of the EL display device of the present embodiment, the layer formed on the bottom surface of the light resonance controlling layer 112 is the color converting layer 111 and the layer formed on the top surface of the light resonance controlling layer 112 is the gate insulating layer 123. The light resonance controlling layer 112 may be arranged between different layers as described above.

[0057] In the structure described above, when the light emitted from the emissive layer included in the intermediate layer 133 undergoes constructive interference within the light resonance controlling layer 112, the strength of the light is increased. The amplified light is emitted to the outside via the color converting layer 111 and the substrate 102, thereby increasing external light coupling efficiency and brightness.

[0058] The refractive index of the color converting layer 111 and the refractive index of the gate insulating layer 123 are each about 1.5; thus, the light resonance controlling layer 112 is made of a material with a refractive index greater than 1.5. Accordingly, the light resonance controlling layer 112 may be made of a sol gel material in which SiN_x , Nb_2O_5 , Ta_2O_5 , or the like with high refractive particles are dispersed.

[0059] In the EL display device including the light resonance controlling layer 112, as described above, the emissive layer included in the intermediate layer 133 emits monochrome light—not red, green, or blue light. The EL display device comprises a separate color converting layer 111 for converting the color of the light emitted from the emissive layer to facilitate the manufacturing of the EL display device.

[0060] For the EL display device, as described above, constructive interference occurs within the light resonance controlling layer 112 when the light within the light resonance controlling layer 112 is in phase, which may be achieved by controlling the thickness of the light resonance controlling layer 112. The thickness of the light resonance controlling layer 112 is determined by the wavelength of the light within the light resonance controlling layer 112. Therefore, the light within the light resonance controlling layer 112 should be single-wavelength light. Thus, if different colored light (i.e., light of different wavelengths) is emitted per sub-pixel, the thickness of the light resonance controlling layer 112 should be different for each of the sub-pixels, resulting in a complex manufacturing process characterized by increased costs and decreased production yield.

[0061] All of the sub-pixels in the EL display device of the present embodiment emit light of the same color (i.e., light of the same wavelength), the light thickness of the resonance controlling layer 112 is set so that the same wavelength light may be amplified, and the amplified light is transmitted through the light resonance controlling layer 112 to display a full color image. As a result, the manufacturing process of the EL display device according to the present invention

may be simplified, manufacturing costs may be reduced, and the production yield of the EL display device may be improved.

[0062] The light resonance controlling layer 112 may be arranged in correspondence with each pixel or sub-pixel, or arranged over all of the pixels as a single layer.

[0063] FIG. 2 is a schematic cross-sectional view of an active matrix EL display device according to a second embodiment of the present invention.

[0064] Referring to FIG. 2, a first electrode 231 is arranged above a substrate 202, a second electrode 234 facing the first electrode 231 is arranged above the first electrode 231, and an intermediate layer 233 including an emissive layer is arranged between the first electrode 231 and the second electrode 234. At least one TFT is connected to the first electrode 231, and a capacitor may be further coupled to the TFT if required. A buffer layer (not shown) made of, for example, SiO_2 may be arranged on the substrate 202 to maintain a smooth surface of the substrate 202 and to prevent penetration of impurities.

[0065] A color converting layer 211 is arranged between the substrate 202 and the first electrode 231, arranged on the second electrode 234, or both. In the present embodiment, the light converting layer 211 is arranged between the substrate 202 and the first electrode 231. The EL display device is a bottom emission EL display device in which light emitted from the emissive layer included in the intermediate layer 233 is emitted to the outside via the substrate 202.

[0066] A light resonance controlling layer 212 is arranged between the emissive layer included in the intermediate layer 233 and the color converting layer 211. In the EL display device of the present embodiment, the light resonance controlling layer 212 is arranged on and substantially parallel to the color converting layer 211 and the intermediate layer 233 including the emissive layer, as illustrated in FIG. 2. Many layers are formed between the emissive layer included in the intermediate layer 233 and the color converting layer 211, as illustrated in FIG. 2. The light resonance layer 212 may be arranged between any of the layers illustrated in the structure of FIG. 2.

[0067] The emissive layer included in the intermediate layer 233 is a light emitting layer which emits light of a single color, and the color converting layer 211 is a layer which converts the light emitted from the emissive layer into a color of light selected from the group consisting of red, green or blue light. The emissive layer included in the intermediate layer 233 may emit blue light. In this case, the color converting layer 211 may convert the blue light into red or green light or transmit the blue light without a color conversion.

[0068] The EL display device of the present embodiment differs from the EL display device of the first embodiment because the light resonance controlling layer 212 of the present embodiment is constructed in a multi-layered structure including two layers, an upper layer 212a and a lower layer 212b, and not in a single layered structure, as described in the first embodiment. Although FIG. 2 only illustrates two layers, upper layer 212a and lower layer 212b in the light resonance controlling layer 212, the light resonance controlling layer 212 may include more than two layers. The light resonance controlling layer 212 may include alternat-

ing a layer with a high refractive index and a layer with a low refractive index. If the light resonance controlling layer 212 includes two layers (i.e., the upper layer 212a and the lower layer 212b), as illustrated in FIG. 2, the upper layer 212a may have a lower refractive index than the refractive index of the first electrode 231 and the lower layer 212b may have a higher refractive index than the refractive index of the upper layer 212a. If the multi-layered light resonance controlling layer 212 is constructed as described above, the light resonance controlling layer 212 may be arranged between any other layers.

[0069] The light resonance layer 212 includes alternating a high reflective index layer and a low reflective index layer, producing light resonance may within the light resonance controlling layer 212 for amplifying and emitting the light to the outside. The greater the difference between the refractive index of the high reflective index layer and the refractive index of the low reflective index, the greater the possibility for light resonance to occur. High refractive index layers of the light resonance controlling layer 212 may be made of a sol gel material in which particles of SiN_x , TiO_2 , Nb_2O_5 , Ta_2O_x , or the like with a refractive index of about 1.5 are dispersed. Low refractive index layers of the light resonance controlling layer 212 may be made of materials such as silicate matrix, methylsiloxanes polymer, siloxane, or Ti-O-Si , polymers such as acrylic polymer or epoxy polymer, oxides such as SiO_2 , HfO_x , or Al_2O_3 , or impurities such as MgF or CaF with an refractive index of about 1.5.

[0070] For the active matrix EL display device of the present embodiment, the emissive layer included in the intermediate layer 233 emits light of a single wavelength, and does not emit red, green, or blue light. To facilitate the manufacturing of the active matrix EL display device, the thickness of the light resonance controlling layer 212 is set so that single-wavelength light may be amplified, and the amplified light is transmitted through the light resonance controlling layer 212 to display a full color image. As a result, a manufacturing process of the EL display device according to the present embodiment may be simplified, manufacturing costs may be reduced, and the production yield of the EL display device may be improved.

[0071] The light resonance controlling layer 212 may be arranged in correspondence with each sub-pixel or pixel, or arranged over all the pixels as a single layer.

[0072] FIG. 3 is a schematic cross-sectional view of a passive matrix EL display device according to a third embodiment of the present invention.

[0073] Referring to FIG. 3, a first electrode 331 is arranged above a substrate 302, a second electrode 334 facing the first electrode 331 is arranged above the first electrode 331, and an intermediate layer 333 including an emissive layer is arranged between the first electrode 331 and the second electrode 334. A buffer layer (not shown) made of, for example, SiO_2 may be arranged on the substrate 302 to maintain a smooth surface of the substrate 302 and to prevent penetration of impurities.

[0074] A color converting layer 311 is arranged between the substrate 302 and the first electrode 331, or arranged on the second electrode 334. In the EL display device of the present embodiment, a color converting layer 311 is arranged between the substrate 302 and the first electrode

331. The EL display device is a bottom emission EL display device in which light emitted from the emissive layer included in the intermediate layer 333 is emitted to the outside via the substrate 302.

[0075] A light resonance controlling layer 312 is arranged between the emissive layer included in the intermediate layer 333 and the color converting layer 311. In the EL display device according to the present embodiment, the light resonance controlling layer 312 is arranged on and substantially parallel to a surface of the color converting layer 311 and the intermediate layer 333 which includes the emissive layer, as illustrated in FIG. 3. Many layers may be arranged between the emissive layer included in the intermediate layer 333 and the color converting layer 311, and the light resonance layer 312 may be arranged between any of those layers.

[0076] The emissive layer included in the intermediate layer 333 is a light emitting layer which emits light of a single color, and the color converting layer 311 converts the light emitted from the emissive layer into a color of light selected from the group consisting of red, green or blue light. The emissive layer included in the intermediate layer 333 may emit blue light. In this case, the color converting layer 311 may convert the blue light into red or green light or transmit the blue light without a color conversion.

[0077] The EL display device according to the present embodiment differs from the active matrix EL display device according to the first embodiment in that the EL display device according to the present embodiment is a passive matrix EL display device. In the first embodiment, the at least one TFT is formed in the EL display device according to the first embodiment and the emission of each sub-pixel is controlled using each TFT. However, in the EL display device of the present embodiment, emission of light at each sub-pixel is controlled by the first electrode 331 and the second electrode 334 arranged in a predetermined pattern, for example, a striped pattern.

[0078] In the EL display device according to the present embodiment, the first electrode 331 is arranged above the substrate 302 in a predetermined pattern, for example, stripes. The intermediate layer 333 including the emissive layer and the second electrode 334 are sequentially arranged on top of the first electrode 331. An insulating layer 332 may be further arranged between the stripes of the first electrode 331 pattern, and the second electrode 334 may be arranged in a pattern perpendicular to the stripes of the first electrode 331. Although not illustrated in FIG. 3, a separate insulating layer may be further formed in a pattern crossing the first electrode 331 perpendicular to the pattern of the second electrode 334. In the EL display device described above, the structures and materials of the first electrode 331, the second electrode 334, and the intermediate layer 333 are the same as described in the previous embodiment.

[0079] The light resonance controlling layer 312 in the EL display device of the present embodiment, having the structure described above, has a single layered structure. The refractive index of the light resonance controlling layer 312 is greater than the refractive indexes of the layer arranged on the top surface of the light resonance controlling layer 312 and the layer arranged on the bottom surface of the light resonance controlling layer 312. In the case of the EL display device of the present embodiment, the layer arranged

on the top surface of the light resonance controlling layer 312 is the first electrode 331 or the insulating layer 332 and the layer formed on the bottom surface of the light resonance controlling layer 312 is the color converting layer 311. The light resonance controlling layer 312 may be arranged between other layers besides the first electrode 331 and the color converting layer 311.

[0080] In the above-described structure, the refractive index of the light resonance controlling layer 312 is greater than the refractive index of the first electrode 331 or the insulating layer 332 arranged on the top surface of the light resonance controlling layer 312 but is less than the refractive index of the color converting layer 311 arranged on the bottom surface of the light resonance controlling layer 312. Therefore, as described above, light output from the emissive layer included in the intermediate layer 333 is amplified and emitted to the outside, increasing external light coupling efficiency and brightness of the EL display device. The light resonance controlling layer 312 is made of the same materials as those described in the previous embodiments.

[0081] Similar to the active matrix EL display device according to the first embodiment, the emissive layer included in the intermediate layer 333 emits light of a single wavelength, and does not emit red, green, or blue light. A separate color converting layer (not shown) is provided to convert the color of the light emitted from the emissive layer. As a result, the thickness of the light resonance controlling layer may be set so that the single wavelength light may be amplified. A manufacturing process of the EL display device according to the present embodiment is simplified, manufacturing costs are reduced, and the production yield of the EL display device may be improved.

[0082] The light resonance controlling layer 312 may be arranged in correspondence with each sub-pixel or each pixel, or may be arranged over all the pixels as a single layer.

[0083] FIG. 4 is a schematic cross-sectional view of an EL display device according to a fourth embodiment of the present invention.

[0084] Referring to FIG. 4, a first electrode 431 is arranged above a substrate 402, a second electrode 434 is arranged above and substantially parallel to the first electrode 431, and an intermediate layer 433 including an emissive layer is arranged between the first electrode 431 and the second electrode 434. A buffer layer (not shown) made of, for example, SiO₂ may be arranged on the substrate 402 to maintain a smooth surface of the substrate 402 and to prevent penetration of impurities.

[0085] The EL display device of the present embodiment differs from the EL display device of the third embodiment because a light resonance controlling layer 412 in the present embodiment does not have a single layer structure, but has a multi-layered structure having an upper layer 412a, an intermediate layer 412b, and a lower layer 412c. Referring to FIG. 4, the light resonance controlling layer 412 includes three layers but may include more than three layers. The light resonance controlling layer 412 may be formed of alternating layers having a high refractive index and low refractive index. If the light resonance controlling layer 412 includes three layers, as illustrated in FIG. 4, the refractive index of the upper layer 412a is less than the refractive index of a first electrode 431 or an insulating layer 432 arranged

on top of the upper layer 412a; the refractive index of the intermediate layer 412b arranged on a bottom surface of the upper layer 412a is greater than the refractive index of the upper layer 412a; and the refractive index of the lower layer 412c is less than the refractive index of the intermediate layer 412b and the refractive index of a color converting layer 411 arranged on a bottom surface of the lower layer 412c. The light resonance controlling layer 412 of the multi-layered structure may be arranged between other layers besides the color converting layer 411 and the first electrode 431 as described above.

[0086] As described above, a single-layered light resonance controlling layer may be used. The greater the difference between the refractive index of the light resonance controlling layer 412 and the refractive index of layers above and below the light resonance controlling layer 412, the greater the possibility for light resonance to occur. Therefore, if it is difficult to use materials to achieve this effect, a multi-layered light resonance controlling layer structure where layers having a high refractive index and layers having a low refractive index are alternatively arranged may be used to achieve the same effect.

[0087] Also, in the active matrix EL display device according to the present embodiment, an emissive layer included in an intermediate layer 433 emits light of a single wavelength, and does not emit red, green, or blue light. The thickness of the light resonance controlling layer 412 may be set so that the single wavelength light may be amplified and transmitted through the color converting layer 411 to display a full color image. As a result, a manufacturing process of the EL display device according to the present embodiment is simplified, manufacturing costs for the EL display device are reduced, and production yield of the EL display device may be improved.

[0088] FIG. 5 is a schematic cross-sectional view of an EL display device according to a fifth embodiment of the present invention. The EL display device of the present embodiment differs from the EL display device of the first embodiment in that the EL display device of the first embodiment includes the color converting layer 112 arranged between the substrate 102 and the first electrode 131 and is a bottom emission EL display device in which the light emitted from the emission layer included in the intermediate layer 133 is emitted to the outside via the substrate 102. However, the EL display device of the present embodiment includes a color converting layer 511 which is disposed above a second electrode 534 and is a top emission EL display device in which light emitted from an emission layer included in an intermediate layer 533 is emitted to the outside via a substrate 502.

[0089] Therefore, in the EL display device of the present embodiment, a first electrode 531 is a reflective electrode and the second electrode 534 is a transparent electrode. Thus, the first electrode 531 may be arranged by arranging a reflective layer using Ag, Mg, Al, Pt, Pd, Au, Ni, Nd, Ir, or Cr and a compound of Ag, Mg, Al, Pt, Pd, Au, Ni, Nd, Ir, or Cr and then forming ITO, IZO, ZnO, or In₂O₃ on the resulting structure. The first electrode 531 may be arranged to correspond with the sub-pixels. The second electrode 534 is made by depositing Li, Ca, LiF/Ca, LiF/Al, Al, or Mg and compounds of Li, Ca, LiF/Ca, LiF/Al, Al, or Mg on the intermediate layer 533 and then arranging a supplementary

electrode layer or a bus electrode line using materials for arranging a transparent electrode such as ITO, IZO, ZnO, or In_2O_3 on the resulting structure. The second electrode 534 may be arranged in correspondence with each sub-pixel or may be arranged over the entire surface of the substrate 502. Top emission EL display devices of other embodiments described below may be structured as described above or may be structured in various other ways.

[0090] A light resonance controlling layer 512 is disposed between the emissive layer included in the intermediate layer 533 and a color converting layer 511. In the EL display device of the present embodiment, the light resonance controlling layer 512 is formed on a surface of the color converting layer 511 facing the intermediate layer 533 including the emissive layer, as illustrated in FIG. 5. There may be various layers formed between the emissive layer included in the intermediate layer 533 and the color converting layer 511, and the light resonance controlling layer 512 may be disposed between any of those layers.

[0091] As described above, the emissive layer included in the intermediate layer 533 may emit monochrome light and the color converting layer 511 converts the light emitted from the emissive layer into a color of light selected from the group consisting of red, green, or blue light. The emissive layer included in the intermediate layer 533 may emit blue light. In this case, the color converting layer 511 may convert the blue light into red or green light or may transmit the blue light without a color conversion.

[0092] A passive matrix EL display device as described above, which is a top emission EL display device, may improve external light coupling efficiency and brightness using the light resonance controlling layer 512. Also, a manufacturing process of the EL display device of the present embodiment may be simplified, manufacturing costs of the EL display device may be reduced, and production yield of the EL display device may be improved by including an emissive layer which emits monochrome light, and using the color converting layer 511.

[0093] As illustrated in FIG. 5, the light resonance controlling layer 512 and the color converting layer 511 are arranged over the entire surface of the substrate 502. However, the light resonance controlling layer 512 and the color converting layer 511 may be patterned to correspond to each sub-pixel, as illustrated in FIG. 6, or the light resonance controlling layer 512 may be patterned to correspond to each sub-pixel while the color converting layer 511 is arranged over the entire area of the substrate 502, as illustrated in FIG. 7. Alternatively, the light resonance controlling layer 512 may be disposed over the entire surface of the substrate 502 while the color converting layer 511 is patterned to correspond to each sub-pixel, as illustrated in FIG. 8.

[0094] As illustrated in FIG. 9, a light resonance controlling layer 612 of a top emission, passive matrix EL display device according to a sixth embodiment of the present invention may be structured to include a plurality of layers in which layers with a high refractive index and layers with a low refractive index are alternately arranged similarly to the bottom emission, active matrix EL display device according to the second embodiment. Also, the same light resonance controlling layer structures may be applied to top emission, active matrix EL display devices illustrated in FIG. 10 and FIG. 11. Although not illustrated in the

drawings, the same light resonance controlling layer structures may be applied to a dual emission EL display device in which light emitted from an emissive layer is emitted to the outside via both sides of the emissive layer.

[0095] According to an EL display device of the present invention, the following may be achieved:

[0096] First, the external light coupling efficiency of light emitted from an emissive layer is increased and brightness of the EL display device may be improved by adjusting the refractive index of a single layered light resonance controlling layer higher or lower than the refractive index of layer arranged above or below the light resonance controlling layer.

[0097] Second, the manufacturing of the light resonance controlling layer may be facilitated by including a multiple layered light resonance controlling layer in which layers with low refractive index and layers with high refractive index are alternately arranged.

[0098] Third, the emissive layer included with the light resonance controlling layer emits light with a single wavelength, a full color display device is configured using a color converting layer, and the light resonance controlling layer is arranged between the emissive layer and the color converting layer. Thus, the EL display device may be easily manufactured, manufacturing costs of the EL display device are reduced, and the production yield of the EL display device is increased.

[0099] It will be apparent to those skilled in the art that various modifications and variations may be made in the present invention without departing from the spirit or scope of the invention. Thus, it is intended that the present invention cover the modifications and variations of this invention provided they come within the scope of the appended claims and their equivalents.

What is claimed is:

1. An electroluminescence luminescence (EL) display device, comprising:

- a substrate;
 - a first electrode arranged above the substrate;
 - a second electrode arranged above the first electrode, the second electrode facing the first electrode;
 - an intermediate layer arranged between the first and second electrodes, and including an emissive layer;
 - a color converting layer arranged between the substrate and the first electrode, or above the second electrode; and
 - a light resonance controlling layer arranged between the emissive layer and the color converting layer.
2. The EL display device of claim 1, wherein the emissive layer emits blue light.
3. The EL display device of claim 1, wherein the color converting layer converts light emitted from the emissive layer into one of a light color selected from the group consisting of red, green, and blue light.
4. The EL display device of claim 1, wherein the light resonance controlling layer is a single layer.
5. The EL display device of claim 4, wherein a refractive index of the light resonance controlling layer is less than

refractive indexes of layers arranged on the light resonance controlling layer and below the light resonance controlling layer.

6. The EL display device of claim 1, wherein the light resonance controlling layer comprises at least two layers.

7. The EL display device of claim 6, wherein the light resonance controlling layer comprises alternating layers having a low refractive index and layers having a high refractive index.

8. The EL display device of claim 6, wherein the color converting layer is arranged between the substrate and the first electrode, and the light resonance controlling layer is arranged between the color converting layer and the first electrode.

9. The EL display device of claim 1, wherein the color converting layer is arranged above the second electrode, and the light resonance controlling layer is arranged between the second electrode and the color converting layer.

10. The EL display device of claim 10, wherein the color converting layer is arranged between the substrate and the first electrode and between the substrate and the second electrode, and the light resonance controlling layer is arranged between the first electrode and the color converting layer and arranged between the second electrode and a color converting layer arranged above the second electrode.

* * * * *

| | | | |
|---------------|---|---------|------------|
| 专利名称(译) | 电致发光显示装置 | | |
| 公开(公告)号 | US20060125389A1 | 公开(公告)日 | 2006-06-15 |
| 申请号 | US11/298569 | 申请日 | 2005-12-12 |
| 申请(专利权)人(译) | 三星SDI CO. , LTD. | | |
| 当前申请(专利权)人(译) | 三星DISPLAY CO. , LTD. | | |
| [标]发明人 | SONG YOUNG WOO KIM YOON CHANG CHO SANG HWAN AHN JI HOON LEE JOON GU LEE SO YOUNG OH JONG SEOK HA JAE HEUNG | | |
| 发明人 | SONG, YOUNG-WOO KIM, YOON-CHANG CHO, SANG-HWAN AHN, JI-HOON LEE, JOON-GU LEE, SO-YOUNG OH, JONG-SEOK HA, JAE-HEUNG | | |
| IPC分类号 | H05B33/00 H05B33/24 H01L51/50 H05B33/12 | | |
| CPC分类号 | H01L27/322 H01L27/3244 H01L51/5262 H01L51/5265 | | |
| 优先权 | 1020040104943 2004-12-13 KR | | |
| 其他公开文献 | US7898167 | | |
| 外部链接 | Espacenet USPTO | | |

摘要(译)

一种电致发光 (EL) 显示装置，其具有改进的外部光耦合效率和亮度，可以容易地制造。EL显示装置包括：基板；第一电极，设置在基板上方；第二电极设置在第一电极上方并基本平行于第一电极；中间层，设置在第一和第二电极之间，并包括发光层；颜色转换层，设置在基板和第一电极之间或第二电极上方；光发射控制层设置在发光层和颜色转换层之间。

